

COMPACT CALIPER BRAKE CB8-H

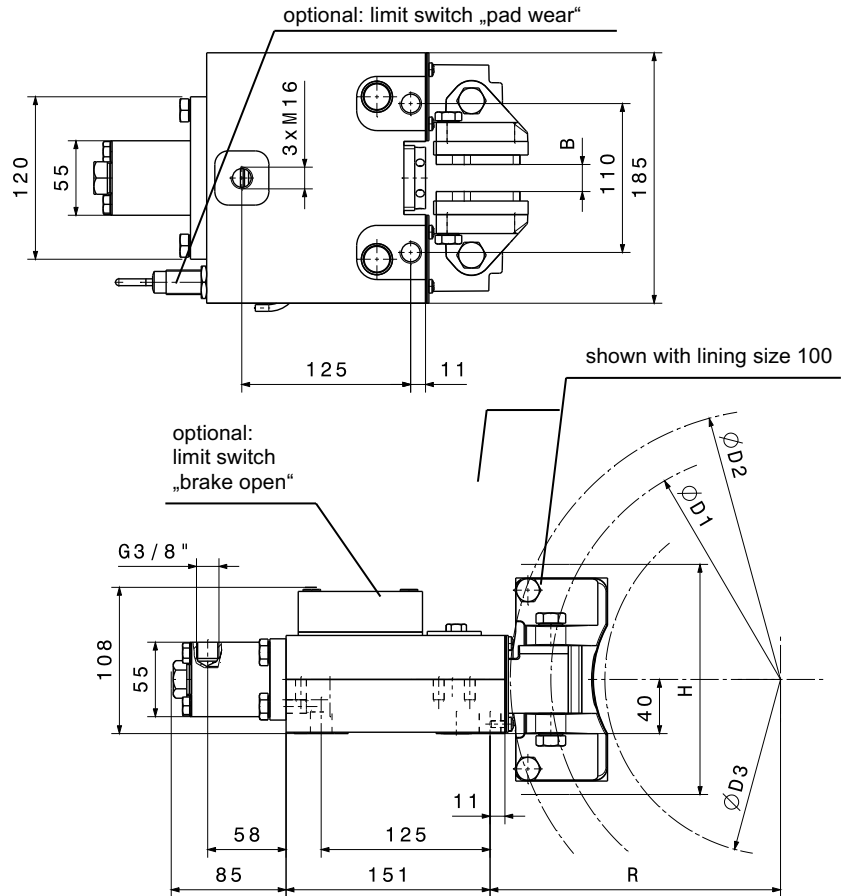

M 1501 331 E-EN-2015-10

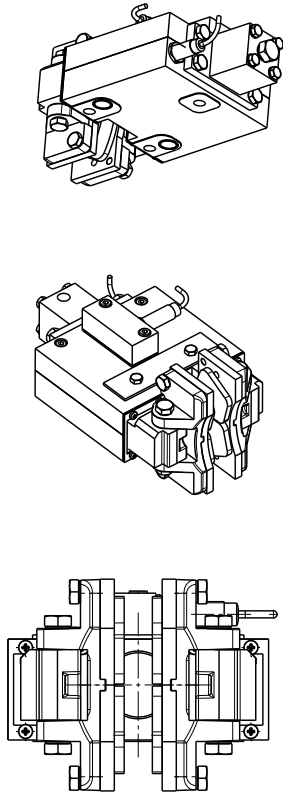

COMPACT CALIPER BRAKE CB8-H FAIL-SAFE, HYDRAULIC RELEASE

options: manual release, sensors „open“ and „pad wear limit“

B = disc width in mm, standard = 20 mm, optional: 12,7; 16; 25; 30

Ø D2 = outer disc diameter in mm

linings: = size 50 standard: organic (suitable for max.circumferential speed $v_{max} = 35\text{m/sec.}$)

= size 50 optional: Sinter

= size 100 standard: Sinter (for discs $D2 \geq \text{Ø}250$)

weight = 22 kg

TECHNICAL DATA FOR INTEGRATED HYDRAULIC CYLINDER

release pressure: 30 bar

max. pressure: 90 bar

piston diameter: 35 mm

max. stroke: 13 mm

(H* for B > 25 mm)

dimensions depending on selected lining size

CB8-H	ØD1	ØD3	R	H (H*)	
-50 (with lining size 50)	ØD2 - 46	ØD2 - 110	D2 / 2 + 19,5	110 (130)	
-100 (with lining size 100)	ØD2 - 60	ØD2 - 140	D2 / 2 + 15	152 (170)	
braking torque in Nm ($\mu = 0,4$) on disc-Ø D2, adjustable from / to					
	Ø 200	Ø 250	Ø 315	Ø 400	Ø 500
CB8-H-50	80-300	110-400	140-530	180-700	n.a.
CB8-H-100	n.a.	350-680	460-910	620-1220	800-1580